

Please read carefully before fitting your new stator to your bike.

Remove existing parts

Remove your existing side case cover containing the existing stator and place case on a clean work surface.

Unscrew the stock stator and pick-up coil from the case. Pull grommet and wiring free and clear from case. Retain all mounting screws and brackets for installing new stator.

Installing your new stator

Place the new stator and pick-up coil into position in the case and fasten with existing brackets and screws. Be sure to use a locking compound on the threads of all mounting screws.

Insert the grommet into position on the side case, and ensure the slide-in bracket is in position. Then install a new gasket onto the side case and install the side case to the engine using existing screws. Torque screws as specified in your service manual.

Troubleshooting

If the engine still does not start, and **before calling technical support**, perform a few basic tests: Re-check the connections. Twisting wires together or taping wires will cause engine inoperability. Check the engine for spark and make sure you have fuel in the tank.

IMPORTANT: If the bike still will not start, reverse the BLACK and RED wires. With the amount of XR's in the field, sometimes the polarity can be reversed.

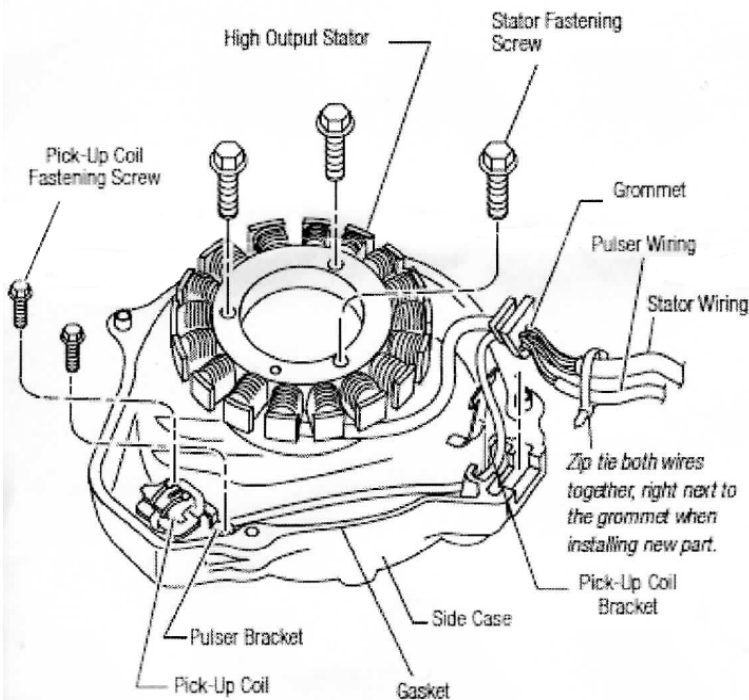

Note: This illustration is a visual representation only. It is not intended to be an exact duplicate of your specific make and model. Please see your service manual for detailed information about your bike including torque specification on all fasteners.

Stock Wiring Configuration

Note:

This stator replaces the original unit and provides a 100W lighting output, as well as a floated coil intended for DC power. The stator can be used with a single 100W headlight, and a single taillight. For maximum output you can use the floated coil for a DC system to charge a battery, or as a secondary AC lighting output.

Step 1

Remove side cover and disconnect the stator leads. Remove the original stator from the sidecover.

Step 2

Mount the new stator in place. It will fit in the same way as the original unit. Feed the leads out. Use locking compound on the screw threads, to prevent the new stator from coming loose.

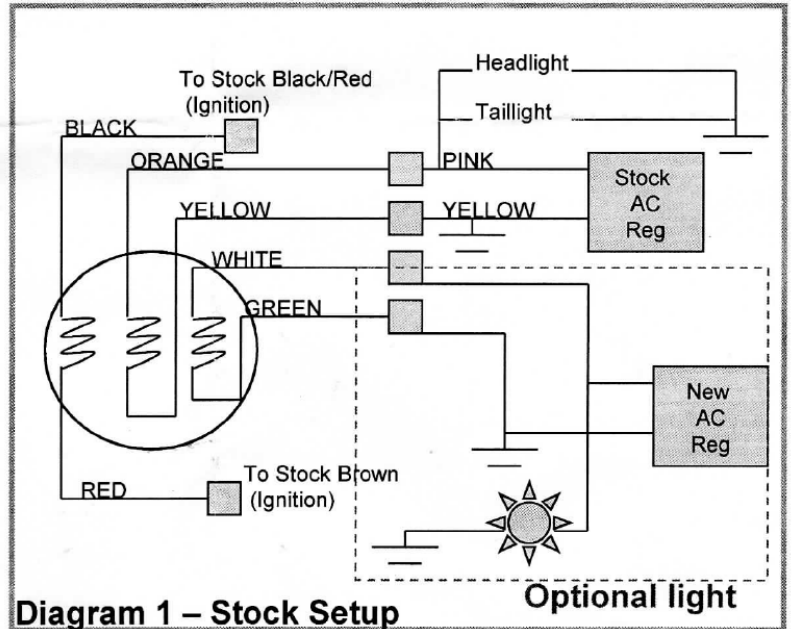

Diagram 1 – Stock Setup

Step 3

Refit the stator cover, and take a look at diagram 1 above for a stock replacement. Connect the stators RED wire to the stock BROWN wire, and connect the stators BLACK wire to the stock BLACK/RED wire. Plug in the 2pin female connector to the stock 2pin male connector. Connect the stators ORANGE wire to the stock PINK wire. Connect the stators YELLOW wire to the stock YELLOW wire. We recommend replacing the original AC regulator with a Moose unit. It is a direct replacement, and can easily handle the high power output of the new stator.

High Power Lighting Circuit / DC

If you look at Diagram 2 you can see the new stator has not one, but two separate outputs.

The ORANGE and YELLOW wires are intended to be used as your stock AC lighting output. They are connected the same in Diagram 1 or 2.

The WHITE and GREEN wires are a floated coil, which can be used to power another AC light as in the red-dashed Optional Light box in Diagram 1.

The WHITE and GREEN wires can also be used to charge a battery for DC lighting or accessories as in Diagram 2.

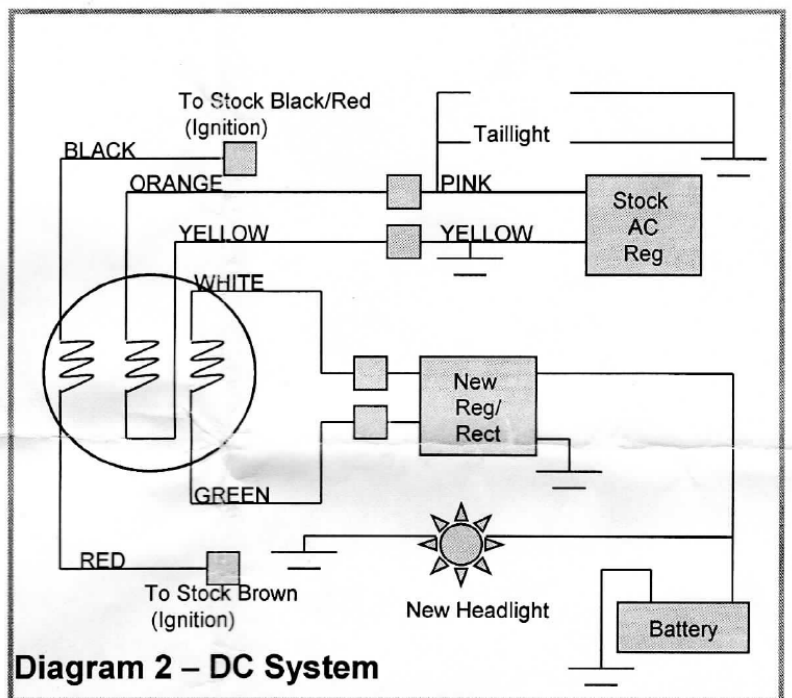

Diagram 2 – DC System